

G-Series

Side Channel

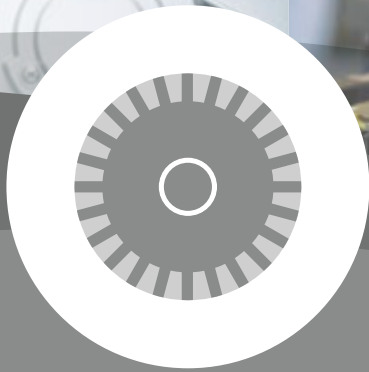

**The Innovation
leader**



G-BH100



G-BH1
single stage



G-BH1
double stage



G-BH2 VELOCIS
single, double and triple stage



G-BH7
single stage



G-BH8
flexible

Side channel blowers

Some technologies are so good that it is hard to improve them. Side channel blowers from Elmo Rietschle are such an example. They have proven their reliability in service for many decades, performing flawlessly day in and day out with virtually no down time. Noise levels have been lower than that of most other vacuum pumps and compressors.

Our side channel blowers are available in a wide selection for performance ranges up to 3,000 m³/h and differential pressures of up to 1,000 mbar. They cover the most varied requirements flexibly and powerfully.

The G-Series side channel blowers feature voltage range motors for 50 and 60 Hz in protection class IP 55 (insulation class F) and are UL 1450 and CAN/CSA C22.2 No. 68-09 approved. This makes them the ideal solution for worldwide use: They can be used without modifications or tests in Europe, Asia and America.

Advantages at a glance

- Reliable and built-to-last, virtually maintenance free
 - > Up to 20,000 operating hours without maintenance down time for G-BH100, G-BH1, G-BH7 and G-BH8
 - > Up to 40,000 operating hours without maintenance down time for G-BH2
- Robust yet light weight
- For use worldwide (UL/CSA/IEC/EN approval)
- 50/60 Hz motors
- ATEX 94/9 EG available for G-BH1 and G-BH7
- Adjustable speed via external or integral frequency converter for all G-BH models



IE2/IE3

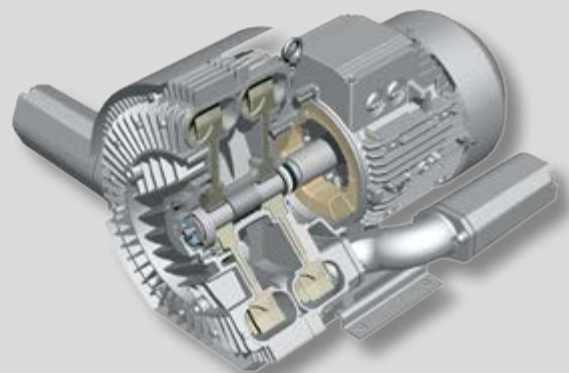

Product overview

G-BH100

The smallest side channel blower on the market

With a height and width of approx. 125 mm and a depth of approx. 60 mm, the G-BH100 blowers are the smallest side channel blowers available on the market.

G-BH1

Classics with innovative technology

With their high inlet volume flow up to 2,500 m³/h and a differential pressure of up to 780 mbar, our low noise G-BH1 side channel blowers have earned their reputation. They are reliable, low maintenance and durable. They deliver 20,000 operating hours without fail and are virtually maintenance free.

IE2 G-BH1 with IE2 motors available on request

G-BH2 VELOCIS

The side channel revolution

Volume flow up to 850 m³/h and differential pressure up to 1,100 mbar. With its significantly expanded range of performance, the side channel technology can now be used in completely new applications.

IE2 The entire G-BH2 VELOCIS range features IE2 motors

Advantages at a glance

- Wear free
- Low operating and energy costs
- Extremely smooth running
- Very low noise level as a result of acoustic engineering
- Dust and fluff resistant
- Pulsation free
- 50/60 Hz voltage range motors
- Operation with frequency converter with 87 Hz
- 40,000 operating hours

G-BH7

Unsurpassed at highest differential pressure

Our G-BH7 side channel blowers can create pressure differences of up to 1,000 mbar – more than any other gas ring compressor! So far, the systems used to reach these differential pressure ranges were much louder and larger – or subject to wear. Now the advantages of wear free operation coupled with a low noise level can also be used in the most demanding applications. The G-BH7 vacuum pumps and compressors can work up to 20,000 hours without maintenance down time. These specialist machines have proven their reliability under the harshest of conditions.

IE2 G-BH7 with IE2 motors on request

G-BH8

Half the size, twice the power

Side channel blower with maximum power/weight ratio and extremely flexible power control (-550 ... +720 mbar)

Technical Highlights

- Lower energy consumption thanks to higher pump efficiency
- Flexible speed drive
- Noise emission reduced by half
- Pulsation free compression
- Virtually maintenance free

IE3 The entire G-BH8 range features IE3 motors

Technical specifications

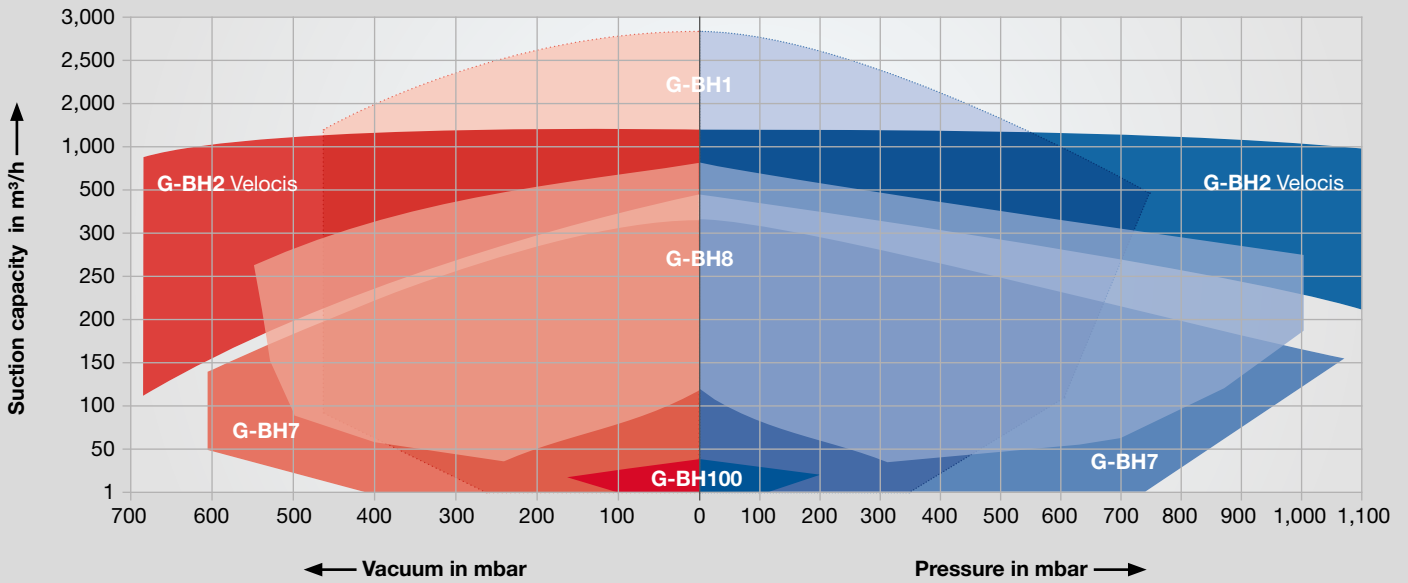

Operating principle

The impellers in the G-Series machines are mounted directly on the motor shaft for contact free compression. Maximum operational reliability, even at high differential pressures, is ensured by the arrangement of the bearings outside the compression chamber.

The gas is taken in through the inlet (1). As it enters the side channel (2), the rotating impellor (3) imparts velocity to the gas in the direction of rotation. Centrifugal force in the impellor blades accelerates the gas outward and the pressure increases. Every rotation adds kinetic energy, resulting in further increase of pressure along the side channel. The side channel narrows at the rotor, sweeping the gas off the impellor blades and discharging it through the outlet silencer (4) where it exits the pump.

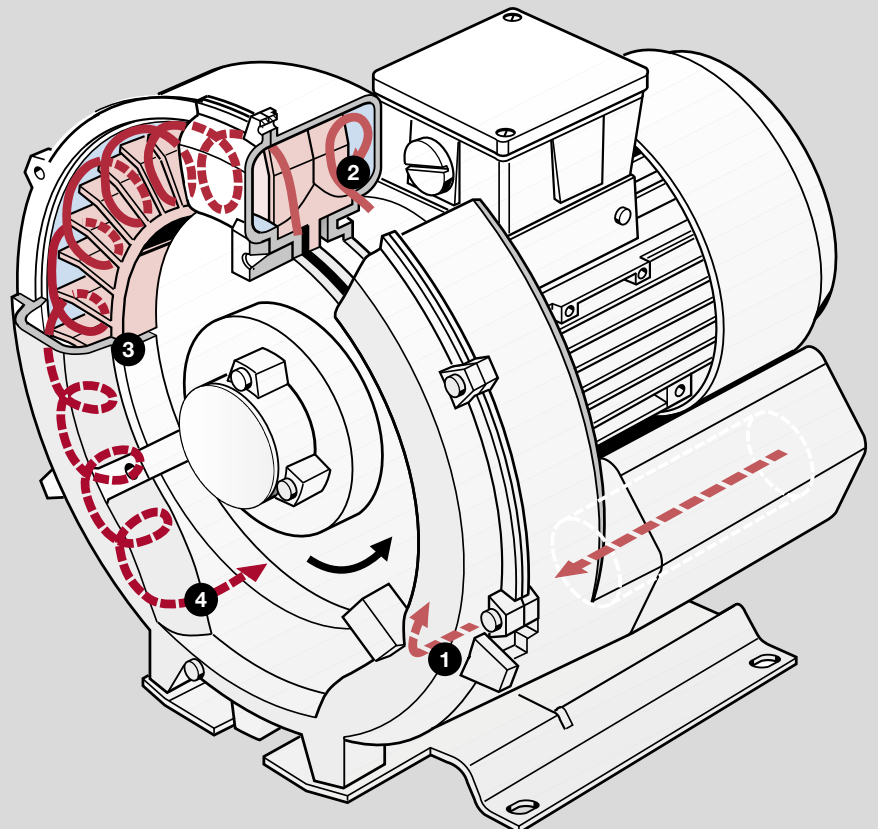



Applications

Central vacuum systems

Degasification of food

Dental vacuum

Drying out buildings

Filling bags / bottles / silos

Fishpond ventilation

Gas analysis

Feeding fish using pellet conveying

Industrial vacuum cleaners

Laser printers

Pneumatic conveying

- Conveying granulated material and powdery media

Letter sorting / enveloping

Lifting and holding parts using vacuum suction

Packaging industry

- Assembling and folding packaging materials
- Vacuum packaging

Plastics industry

- Contact free plastic film redirection
- Cooling and drying extruder products
- EPS foaming
- Granulate conveying
- Plastic welding
- Thermoforming

Printing and paper industry

- Sheet separation, turning, transport, fixation, and drying

Soil remediation

Swimming pool technology / jacuzzis

Textile industry

Ventilation of sewage treatment plants

Gardner Denver



- Corporate Headquarters
- Sales / Service Location
- Manufacturing Location
- Our Partners

www.gd-elmorietschle.com
www.gd-industrials.com
er.de@gardnerdenver.com

**Gardner Denver
Schopfheim GmbH**
 Roggenbachstrasse 58
 79650 Schopfheim · Germany
 Phone +49 7622 392-0
 Fax +49 7622 392-300

**Gardner Denver
Deutschland GmbH**
 Industriestrasse 26
 97616 Bad Neustadt · Germany
 Phone +49 9771 6888-0
 Fax +49 9771 6888-4000



F-Series
Radial



G-Series
Side Channel



L-Series
Liquid Ring



V-Series
Rotary Vane



R-Series
Rotary Lobe



C-Series
Claw



S-Series
Screw



X-Series
Systems